

# XEVL-2011-E1RS

Model

CHEFTOP MIND.Maps Big One

- Combi steamer
- Electric
- 20 Trays GN 1/1
- Hinged left (Right Hand Door)
- 7" Touch control panel



## STANDARD COOKING FEATURES

### Settings

- **TEMPERATURE:** 30 °C – 260 °C.
- **CLIMA.Control:** Humidity or dry air set by 10%.
- Single.Point core probe.
- Delta T cooking with core probe.
- **MIND.Maps™:** Draw cooking processes made of infinite steps with one simple touch.

### Programs

- 1000+ programs.

### Unox intensive cooking

- **STEAM.Maxi™:** Humidity and steam production.
- **DRY.Maxi™:** Forced extraction of humidity.

## APP & WEB SERVICES

- Data Driven Cooking App & webApp.
- Top Training App.
- Combi guru App.

## DESCRIPTION

Horno combinado tecnológicamente avanzado para la cocina gastronómica procesos (deshidratación, cocción al vapor, cocción a baja temperatura, sous vide cocinar, asar, asar a la parrilla, freír, regenerar y planchar regeneración) y para el proceso de horneado fresco o congelado gracias a las tecnologías CLIMALUX™, STEAM.Maxi™, DRY.Maxi™ y AIR.Maxi

## KEY FEATURES

### Data driven cooking

- **Ethernet:** connection board to keep the oven connected to UNOX cloud and UNOX App.
- **DDC Stats:** Oven usage and consumption reports.
- On-line recipe book and possibility to send programs to ovens.

### Unox intensive cooking

- **STEAM.Maxi™:** Humidity and steam production.
- **DRY.Maxi™:** Forced extraction of humidity.
- **AIR.Maxi™:** Multiple fans and auto-reversing fan speed.

## STANDARD TECHNICAL FEATURES

- **ROTOR.Klean™** : automatic washing system.
- **Single.Point core probe:** 4 sensors.
- **Double glass**
- **WI-FI-/USB data:** download/upload HACCP data.
- **WI-FI-/USB data:** download/upload programs
- Integrated Det&Rinse tank.
- **LED:** chamber illumination integrated in the door.
- Tray supports with anti-tipping system
- Stainless steel AISI 304 cooking chamber



RHOSTELEV, S.L.

Trav. C/ Fusteria a C/ Clavo, 23. P.I. Canastell 03690 San Vicente del Raspeig- TLF. 965.672.724 - 649.149.245

C/ Venezuela, 0017 DH-10 nave 8ª par. P.I. Oeste. 30820 Alcantarilla (MURCIA), TLF. 601.327.244 - 868.454.195

# XEVL-2011-E1RS

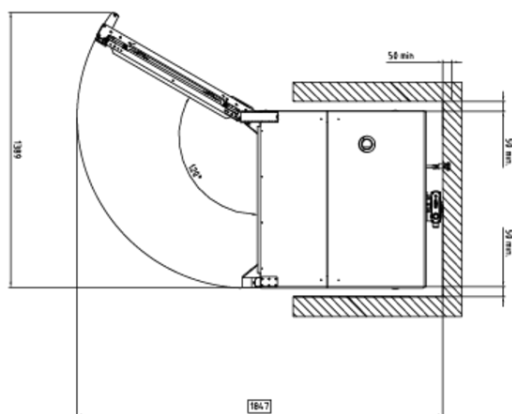
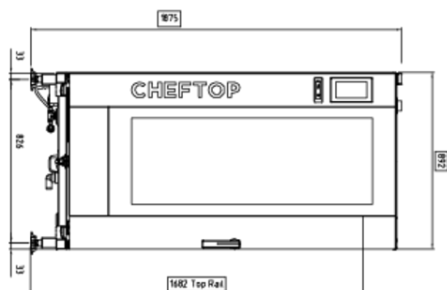
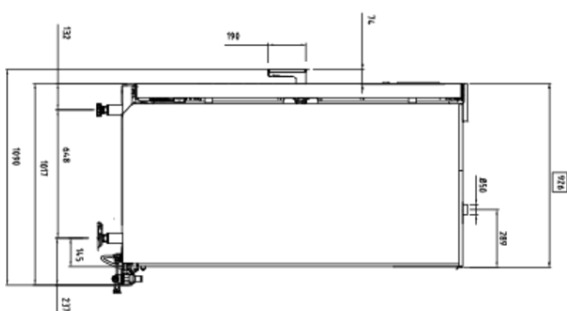
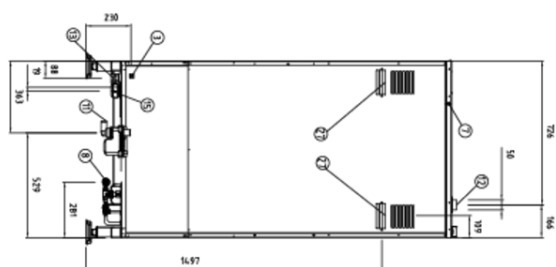

## DIMENSIONS AND WEIGHT

Width:	892 mm
Depth:	1018 mm
Height:	1875 mm
Net Weight:	292 Kg
Pan Spacing:	67 mm

## CONNECTION POSITIONS

1	Terminal board cover box
2	Terminal board power supply
3	Unipotential terminal
6	Technical data plate
7	Safety thermostat
8	3/4 " Thread water inlet
9	3/4" Gas inlet
10	Rotor.KLEAN connection
11	Cavity drain pipe
12	Hot fumes exhaust chimney
13	Accessories connection
27	Cooling air outlet

RHOSTELEV, S.L.

Trav. C/ Fusteria a C/ Clavo, 23. P.I. Canastell 03690 San Vicente del Raspeig- TLF. 965.672.724 - 649.149.245

C/ Venezuela, 0017 DH-10 nave 8ª par. P.I. Oeste. 30820 Alcantarilla (MURCIA), TLF. 601.327.244 - 868.454.195

# XEVL-2011-E1RS

## POWER AND GAS SUPPLY

### STANDARD

Voltage	380-415 V
Phase	3PH+N+PE
Cycle	50-60 Hz
Total power	29.3 kW
Maximum Amp Draw	43.5 A
Required breaker size *	50 A
Power cable requirement	H07RN-F 5G 10 mm <sup>2</sup>
Cord diameter	13,96 mm
Plug	NOT INCLUDED

### OPTION A

Voltage	220-240 V
Phase	3PH+PE
Cycle	50-60 Hz
Total power	29.3 kW
Maximum Amp Draw	74 A
Required breaker size *	25 A
Power cable requirement	H07RN-F 4G 16 mm <sup>2</sup>
Cord diameter	13,96 mm
Plug	NOT INCLUDED

## INSTALLATION REQUIREMENTS

Installations must comply with all local electrical systems, particularly as for minimum wire gauge required for field connection, hydraulic and ventilation supply.

Exhaust and fume analysis must be performed in case of gas ovens.

## WATER CONNECTION

### Supply

USING A WATER SUPPLY NOT MEETING UNOX'S MINIMUM WATER QUALITY STANDARDS WILL VOID ANY WARRANTY.

It is the responsibility of the purchaser to ensure that the incoming water supply is compliant with the specifications listed through adequate treatment measures.

Line pressure:	Drinking water inlet: 3/4" NPT*, line pressure: 21 to 87 psi; 1.5 to 6 Bar
----------------	--

### Inflow water specifications

Free chlorine	≤ 0.2 ppm
Chloramine	0.1 ppm
pH	7 ÷ 8.5

### Steam circuit: inflow water specifications

Total hardness (TH)	≤ 8 °d
Chlorides	≤ 25 ppm
Alkalinity	≤ 150 ppm as CaCO <sub>3</sub>

### Clean circuit: inflow water specifications

Total hardness (TH)	≤ 20 °d
Chlorides	≤ 80 ppm
Alkalinity	≤ 250 ppm as CaCO <sub>3</sub>

## ACCESSORIES

- **Det&Rinse PLUS** Concentrated detergent and rinse aid
- **Det&Rinse ECO** detergent with natural ingredient
- **VENTLESS HOOD** Steam condensing hood (water required)
- **Activated Carbon filter for waterless hoods**
- **COOKING ESSENTIALS** Special trays
- **Quick load and trolley system**
- **UNOX PURE** Osmosis filter
- **UNOX PURE-RO** Reverse osmosis filter
- **Sous-vide** extra-fine core probe for sous-vide
- **Wi/Fi** Connection board to keep the oven connected to UNOX cloud mandatory to extend warranty
- **HYPER.Smoker** Smoker box for wood chips and sawdust to smoke inside the cooking chamber without extra electrical supply
- **Available in different voltage**

RHOSTELEV, S.L.

Trav. C/ Fusteria a C/ Clavo, 23. P.I. Canastell 03690 San Vicente del Raspeig- TLF. 965.672.724 - 649.149.245

C/ Venezuela, 0017 DH-10 nave 8ª par. P.I. Oeste. 30820 Alcantarilla (MURCIA). TLF. 601.327.244 - 868.454.195